

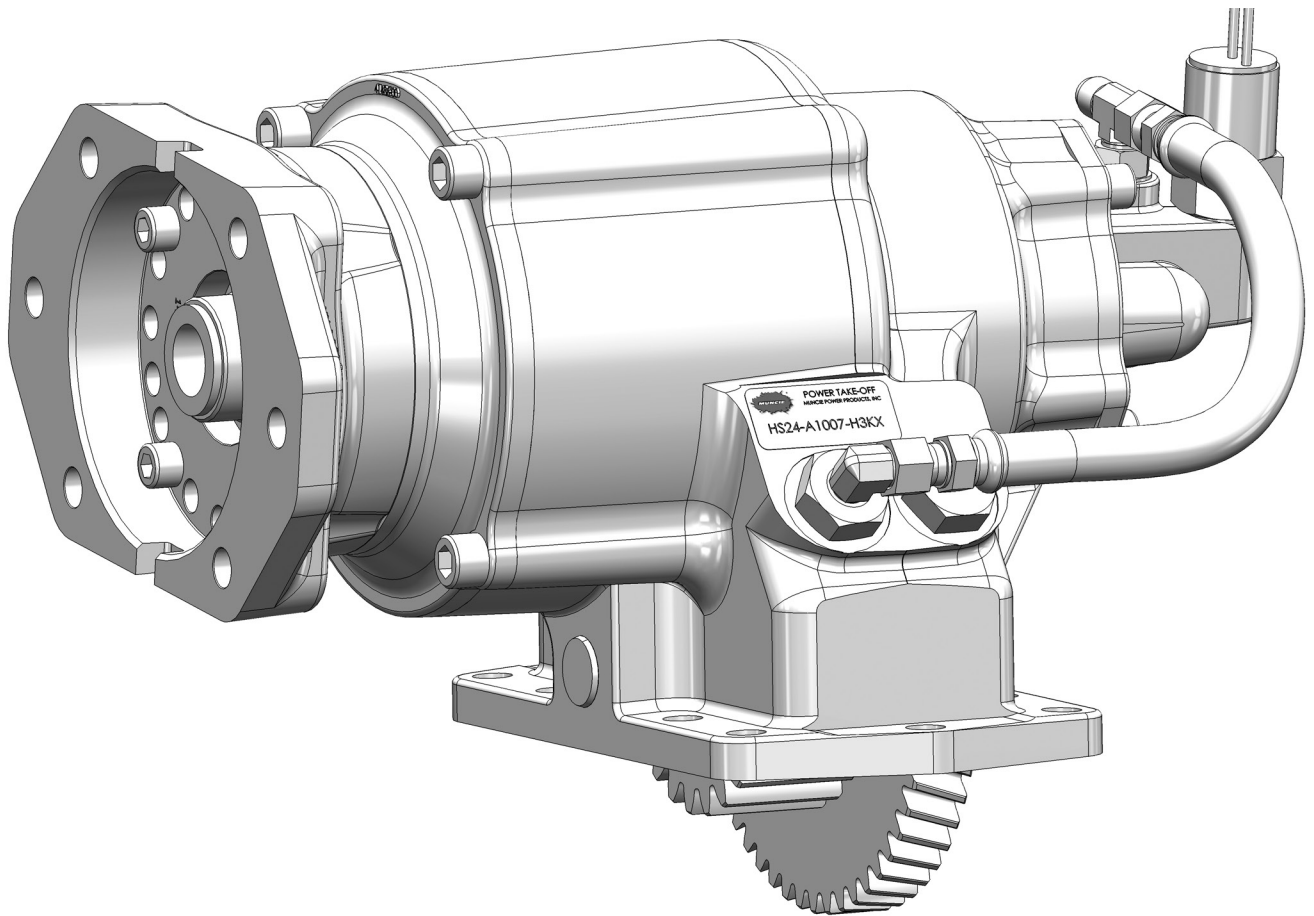

# HS24 SERIES PTO

## PARTS LIST AND SERVICE MANUAL



# EXPLODED VIEWS

## HS24 SERIES PTO

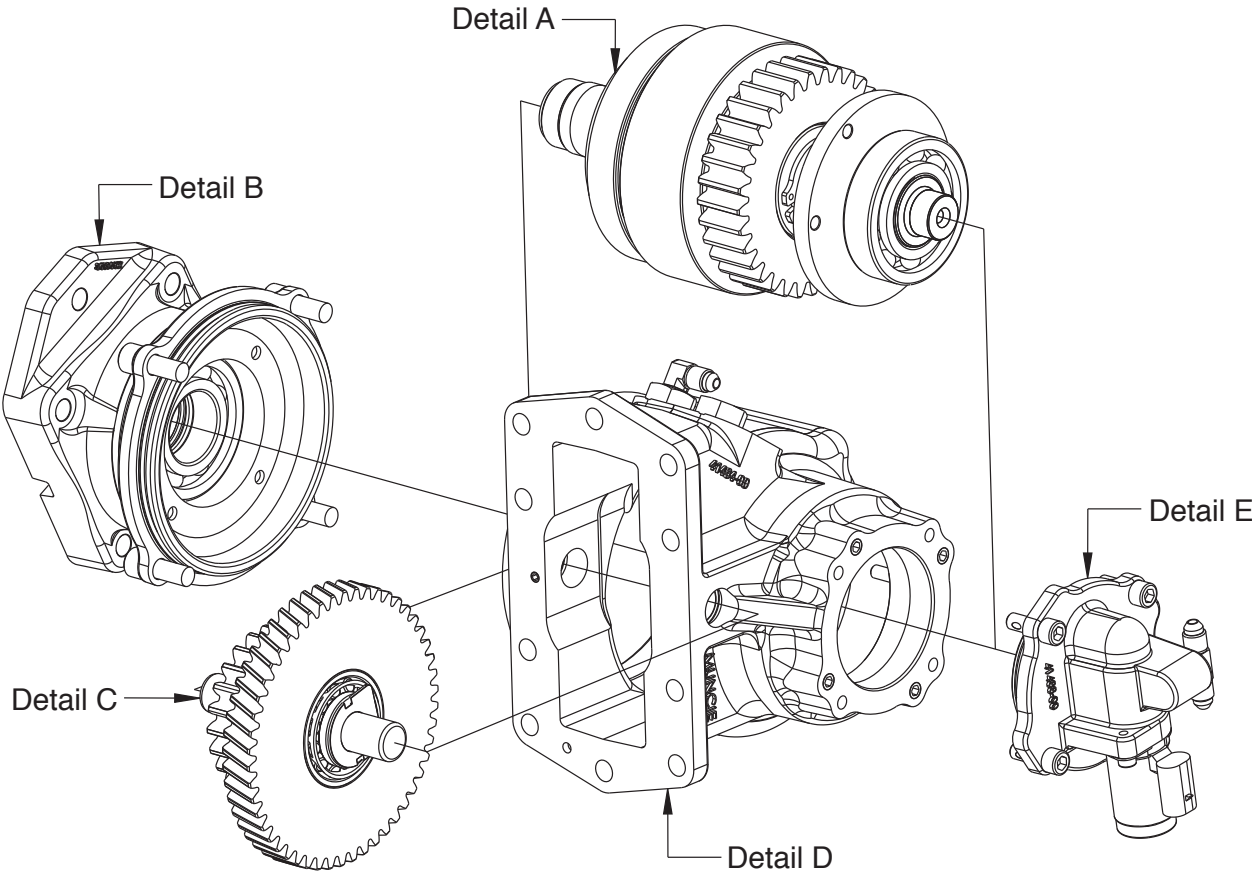

### DETAIL A - OUPUT SHAFT ASSEMBLY

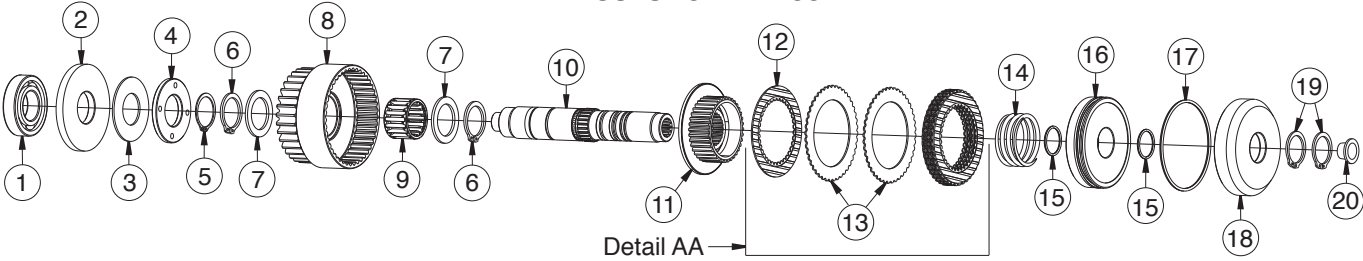

\* The standard clutch pack assembly contains a pair of stator plates stacked between each friction disk. The assembly should begin and end with a friction disk.

### DETAIL AA - CLUTCH PACK ASSEMBLY (DISC LOCATION)\*

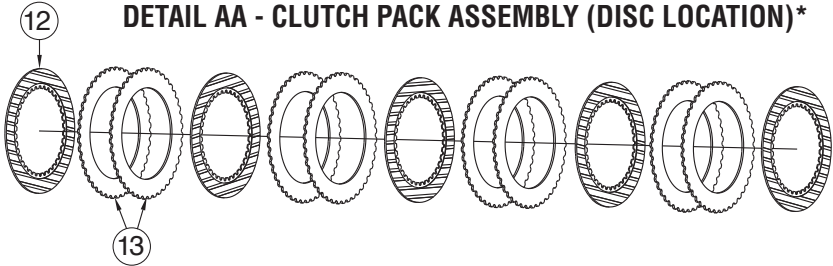

# EXPLODED VIEWS

## DETAIL B - OUTPUT OPTIONS

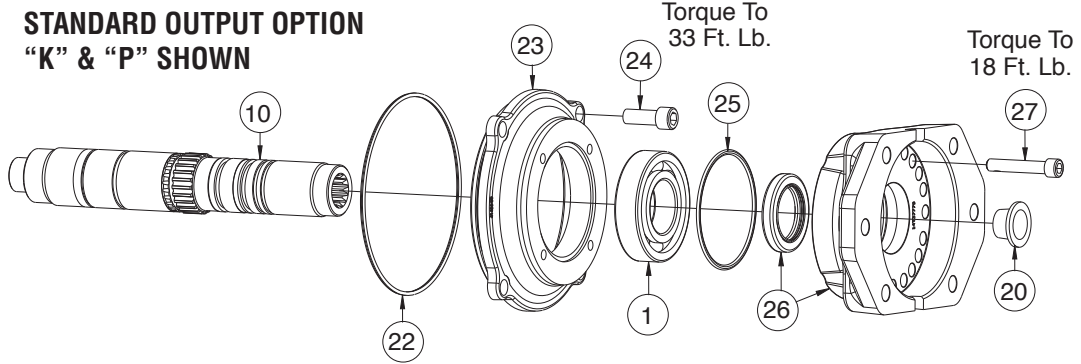
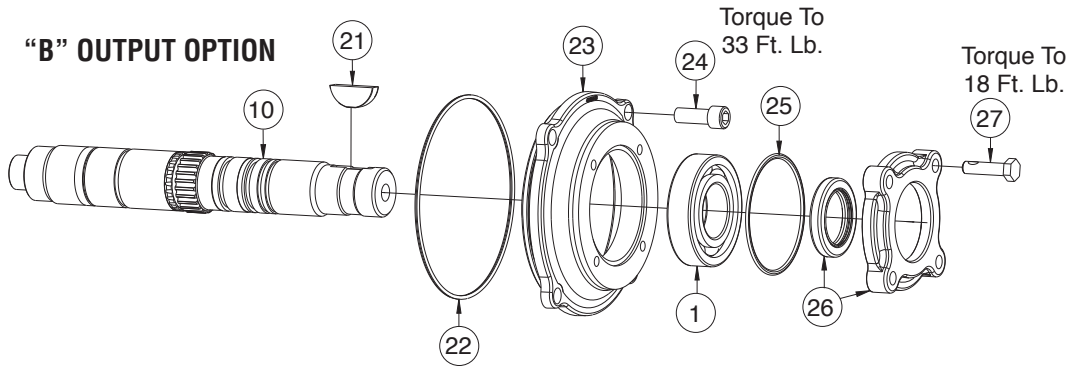

## DETAIL C - INPUT SHAFT ASSEMBLY

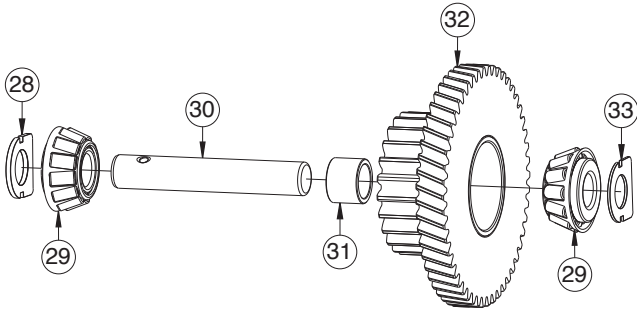

## DETAIL D - PTO HOUSING ASSEMBLY

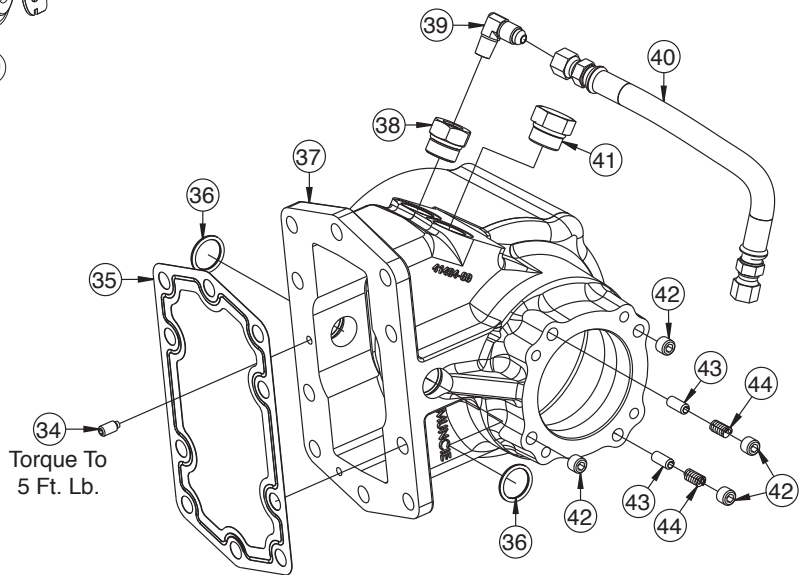

## DETAIL E - END COVER ASSEMBLY

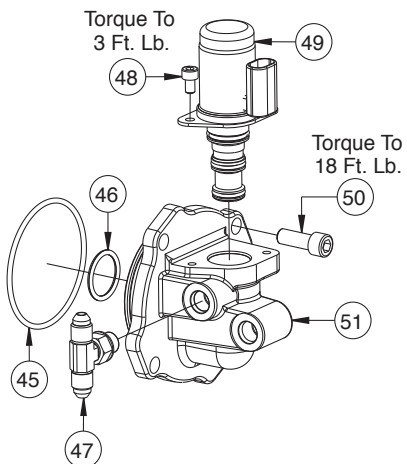

# PARTS LIST AND DESCRIPTION

ITEM	QTY	PART NO.	DESCRIPTION
<b>Detail A</b>			
01	2	10T21017	Bearing
02	1	21T36473	Plate
03	1	21T36511	Washer
04	1	21T36512	Brake Plate
05	1	24T27240	Snap Ring
06	2	24T35480	Snap Ring
07	2	21T29017	Thrust Washer
08	1	See Table A	Bell Gear
09	1	10T36285	Needle Bearing
10	1	See Table B	Output Shaft
11	1	02T38792	Clutch Hub
12	5	49T33564	Friction Disc
13	8	49T40641	Spacer Disc
14	1	27T36112	Spring
15	2	12T36471	O-Ring
		12T42608	O-Ring (I or D output)
16	1	49T36463	Piston
		49T42607	Piston (I or D output)
17	1	12T36472	O-Ring
18	1	49T36464	Piston Cup
		49T42606	Piston Cup (I or D output)
19	2	24T36470	Snap Ring
20	1	25T35724	Cap Plug "K", "Q", "S" & "6"
	1	25T35725	Cap Plug "P"
	1	25T37387	Cap Plug "T"
<b>Detail B</b>			
21	1	26T01627	Woodruff Key "B"
22	1	12T36197	O-Ring
23	1	15T41487	Output Cover
		15T42605	Output Cover (I or D)
24	4	19M38100	Socket Capscrew
25	1	12T36751	O-Ring
26	1	See Table C	Flange/Seal Kit
27	4	19T39417	Hex Capscrew "B"
	4	19T34462	Socket Capscrew "K", "P" & "6"
	4	19T39257	Socket Capscrew "Q", "S" & "T"
<b>Detail C</b>			
28	1	18T41452	Input Bearing Shim
29	2	10T35776	Roller Bearing
30	1	07T35780	Input Shaft
31	1	See Table D	Cone Spacer
32	1	See Table E	Input Gear
33	1	See Table F	Input Bearing Shim

ITEM	QTY	PART NO.	DESCRIPTION
<b>Detail D</b>			
34	1	19T35785	Set Screw
35	1	13T35777	Gasket
36	2	12T35774	O-Ring
37	1	01T41485	PTO Housing (3 Arrg)
		01T42373	PTO Housing (1 Arrg)
38	1	25T35784	Lubrication Plug
39	1	43T35867	Elbow
40	1	45T36308	Hose
41	1	25T35999	Plug
42	4	19T36174	Set Screw
43	2	26T36175	Roll Pin
44	2	27T36173	Spring
<b>Detail E</b>			
45	1	12T36873	O-Ring
46	1	12T36081	O-Ring
47	1	43T36231	Tee Fitting
48	1	19T40859	Socket Capscrew
49	1	35T40860	Solenoid Valve
50	4	19T36588	Socket Capscrew
51	1	15T41489	Bearing Cover
<b>KITS</b>			
N.S.	1	48TK5217	<b>Installation Kit (12V) includes:</b> Shift Kit, Gasket Kit, Stud Kit & Std. Hose Kit
N.S.	1	48TK5219	<b>Installation Kit (24V) includes:</b> Shift Kit, Gasket Kit, Stud Kit & Std. Hose Kit
N.S.	1	48TK5235	<b>Installation Kit (12V) includes:</b> Shift Kit, Gasket Kit, Stud Kit & Special Hose Kit (17")
N.S.	1	48TK4708	<b>Installation Kit (12/24V) "P" Option Includes:</b> Shift Kit, Gasket Kit, Stud Kit, Std. Hose Kit, Pressure Switch & Pressure Switch Fittings
N.S.	1	HS24-GSK	<b>Gasket Kit includes:</b> (2)15, (1)17, (1)22, (1)25, (1)35, (2)36, (1)45, (1)46 & (1)11T37790
N.S.	1	HS24-RBK	<b>Rebuild Kit includes:</b> (2)1, (1)3, (1)5, (2)6, (2)7, (5)12, (8)13, (1)14, (2)15, (1)17, (2)19, (1)22, (1)25, (1)28, (2)29, (1)35, (2)36, (2)44, (1)45, (1)46 & (1)11T37790

## TABLE DETAIL PARTS AND DESCRIPTIONS

**TABLE A – BELL GEAR (Item 8)**

PART NO.	DESCRIPTION
02T41789	Bell Gear 06 (36T)
02T41790	Bell Gear 07 (33T)
02T41791	Bell Gear 09 (30T)
02T41792	Bell Gear 12 (26T)

**TABLE B – OUTPUT SHAFT (Item 10)**

PART NO.	DESCRIPTION
06T36892	Output Shaft "B" 1.3" Rd.
06T36893	Output Shaft "K" & "6" 7/8" – 13T SPL
06T37089	Output Shaft "P" 1" – 15T SPL
06T37090	Output Shaft "Q" & "S" 7/8" – 13T SPL
06T37336	Output Shaft "T" 3/4" – 11T SPL

**TABLE E – INPUT GEAR (Item 32)**

PART NO.	DESCRIPTION	GEAR NO.
03TA5276	A1006 Input Gear (50T/20T)	03T41778
03TA5277	A1007 Input Gear (50T/23T)	03T41687
03TA5278	A1009 Input Gear (50T/26T)	03T41779
03TA5279	A1012 Input Gear (50T/30T)	03T41780

# MODEL NUMBER CONSTRUCTION

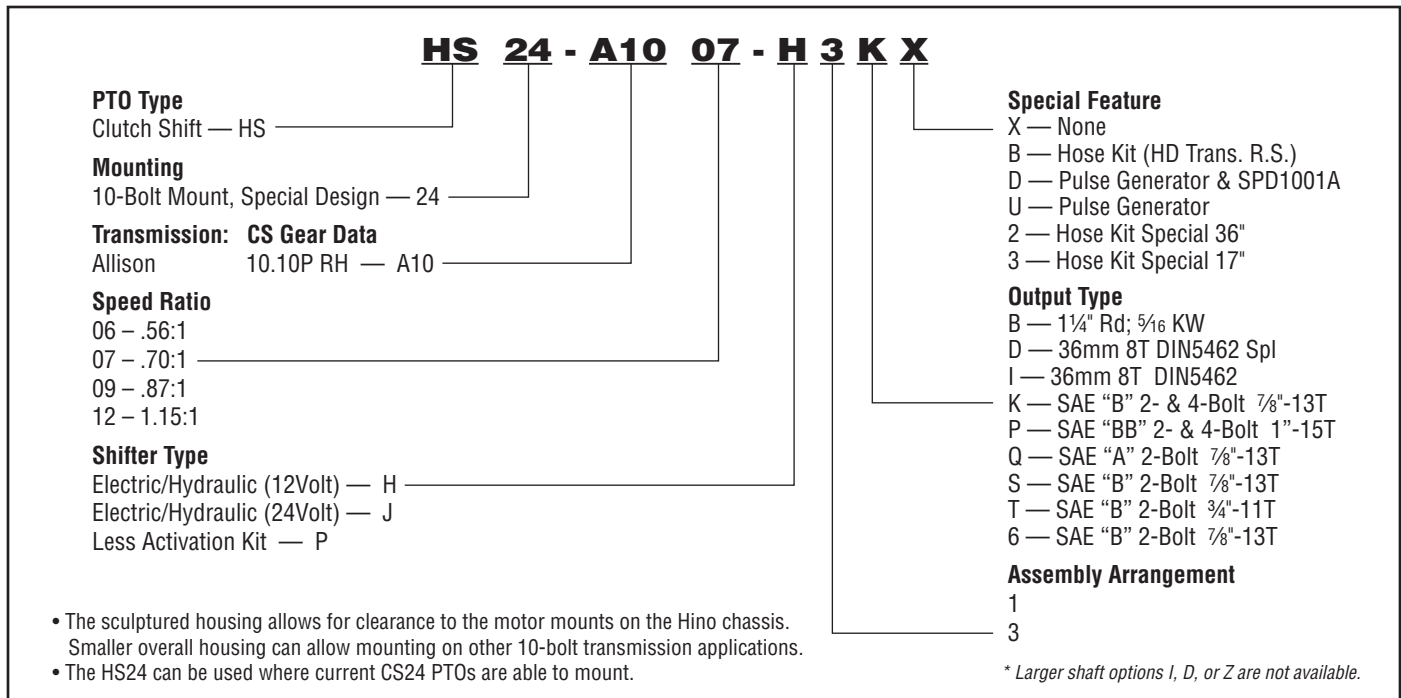

## TABLE DETAIL PARTS AND DESCRIPTIONS

**TABLE C – OUTPUT COVER/FLANGE (Item 26)**

PART NO.	DESCRIPTION	DIMENSION
15TA5220	"B" Flange/Seal Assembly	Includes: 15T41683 Bearing Cap & 11T37790 Output Shaft Seal
14TA3996	"K" & "P" Flange/Seal Assembly	Includes: 14T37779 Hydraulic Flange & 11T37790 Output Shaft Seal
14TA3997	"Q" & "T" Flange/Seal Assembly	Includes: 14T39141 Hydraulic Flange & 11T37790 Output Shaft Seal
14TA3999	"S" Flange/Seal Assembly	Includes: 14T35464 Hydraulic Flange & 11T37790 Output Shaft Seal
14TA4819	"6" Flange/Seal Assembly	Includes: 14T38981 Hydraulic Flange & 11T37790 Output Shaft Seal

**TABLE D – CONE SPACER (Item 31) Only 1 is used**

PART NO.	DESCRIPTION	DIMENSION
18T38748	Cone Spacer	(0.743" / 0.741")
18T38532	Cone Spacer	(0.740" / 0.738")
18T38533	Cone Spacer	(0.737" / 0.735")
18T38534	Cone Spacer	(0.734" / 0.732")
18T38535	Cone Spacer	(0.731" / 0.729")
18T38536	Cone Spacer	(0.728" / 0.726")
18T38537	Cone Spacer	(0.725" / 0.723")
18T38538	Cone Spacer	(0.722" / 0.720")
18T38539	Cone Spacer	(0.719" / 0.717")
18T38540	Cone Spacer	(0.716" / 0.714")
18T38590	Cone Spacer	(0.713" / 0.711")
18T38591	Cone Spacer	(0.710" / 0.708")
18T38592	Cone Spacer	(0.707" / 0.704")

The cone spacer installs between the tapered input bearings to set the bearing preload at .002" - .006" loose. [Critical dimension]. See pages 3 & 10 for details.

Purchase input gear assembly (Item 32 - 03TA\*\*\*\*) which includes the correct cone spacer.

**TABLE F – INPUT BEARING SHIM (Item 33) Only 1 is used**

PART NO.	DESCRIPTION	DIMENSION
18T41437	Bearing Shim	(0.1150" / 0.1130")
18T41438	Bearing Shim	(0.1175" / 0.1155")
18T41439	Bearing Shim	(0.1200" / 0.1180")
18T41440	Bearing Shim	(0.1225" / 0.1205")
18T41441	Bearing Shim	(0.1250" / 0.1230")
18T41442	Bearing Shim	(0.1275" / 0.1255")
18T41443	Bearing Shim	(0.1300" / 0.1280")
18T41444	Bearing Shim	(0.1325" / 0.1305")
18T41445	Bearing Shim	(0.1350" / 0.1330")
18T41446	Bearing Shim	(0.1375" / 0.1355")
18T41447	Bearing Shim	(0.1400" / 0.1380")
18T41448	Bearing Shim	(0.1425" / 0.1405")
18T41449	Bearing Shim	(0.1450" / 0.1430")
18T41450	Bearing Shim	(0.1475" / 0.1455")
18T41451	Bearing Shim	(0.1500" / 0.1480")



# HS24 INSTALLATION KITS

## ELECTRIC/HYDRAULIC WITHOUT OVERSPEED SWITCH

48TK5217 — 12 Volt with Direct Activation Solenoid • 48TK5219 — 24 Volt with Direct Activation Solenoid

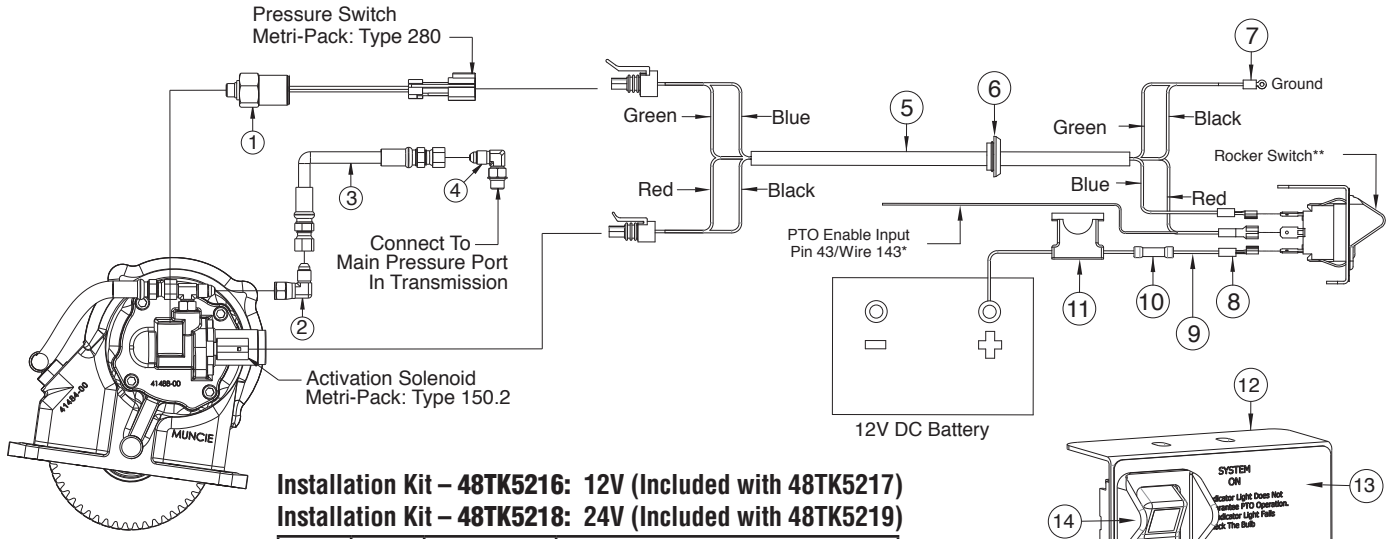

Installation Kit – 48TK5216: 12V (Included with 48TK5217)  
 Installation Kit – 48TK5218: 24V (Included with 48TK5219)

ITEM	QTY.	PART NO.	DESCRIPTION
1	1	30T41642	Pressure Switch
2	1	43T36445	Elbow (Use as needed)
3	1	45T36274	Hose Assembly - Standard 28"
4	1	43M68014	Elbow (Transmission Pressure Ports)
5	1	34T40902	Wire Harness
6	1	37T35674	Grommet
7	2	34M18009	Ring Terminal
8	1	34M18250	Female Spade Connector (1/4")
9	6 FT.	37M18000	Wire
10	1	34M18002	Butt Splice
11	1	33T36299	Fuse Assembly
12	1	36MA1005	Switch Bracket
13	1	36T36271	Face Plate without Light access
13a	1	36M01006	Face Plate with Overspeed Light
14	1	30T35687	Rocker Switch - 12 Volt
14a	1	30T35712	Rocker Switch - 24 Volt
15	1	32MSR12V	Light Assembly - 12 Volt
15a	1	32MSR24V	Light Assembly - 24 Volt
16	3	34M18187	Female Spade Connector (3/16")

### \* Allison TCM (Pin 43)

Clutchshift PTOs require a connection to the Allison "PTO Enable Input" circuits. Check the vehicle dealer or body builder's information for this location.

### \*\*Rocker Switch

Green light in the rocker switch is to turn "ON" when the PTO is engaged and turn "OFF" when the PTO is disengaged.

### For 24 Volt Option — 48TK5218

Include items 12 & 13 and substitute items 14 & 15 with 14a & 15a.

### Overspeed Option

Items 13 (faceplate with light access) & 15 (12V light) are not included in 30T36270 (12V bracket assembly) and are to be ordered separately in kit 36TK4971.

## ELECTRIC/HYDRAULIC WITH OVERSPEED SWITCH

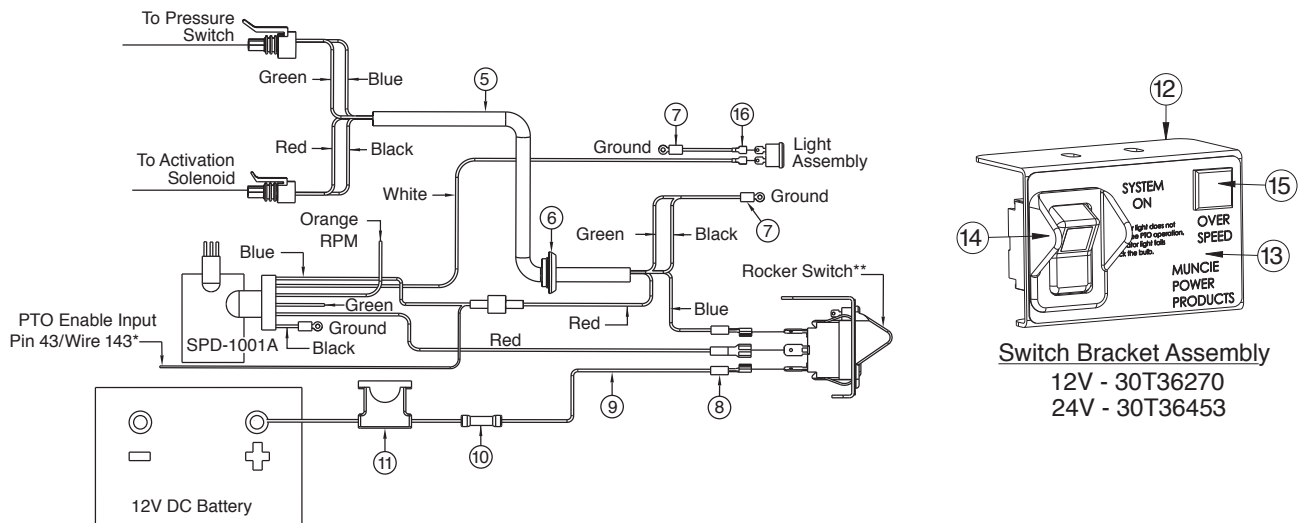

Switch Bracket Assembly  
 12V - 30T36270  
 24V - 30T36453

# HS24 PTO DIMENSIONS IN INCHES (MM)

## "B" OUTPUT OPTION — 1 1/4" Round Keyed Shaft

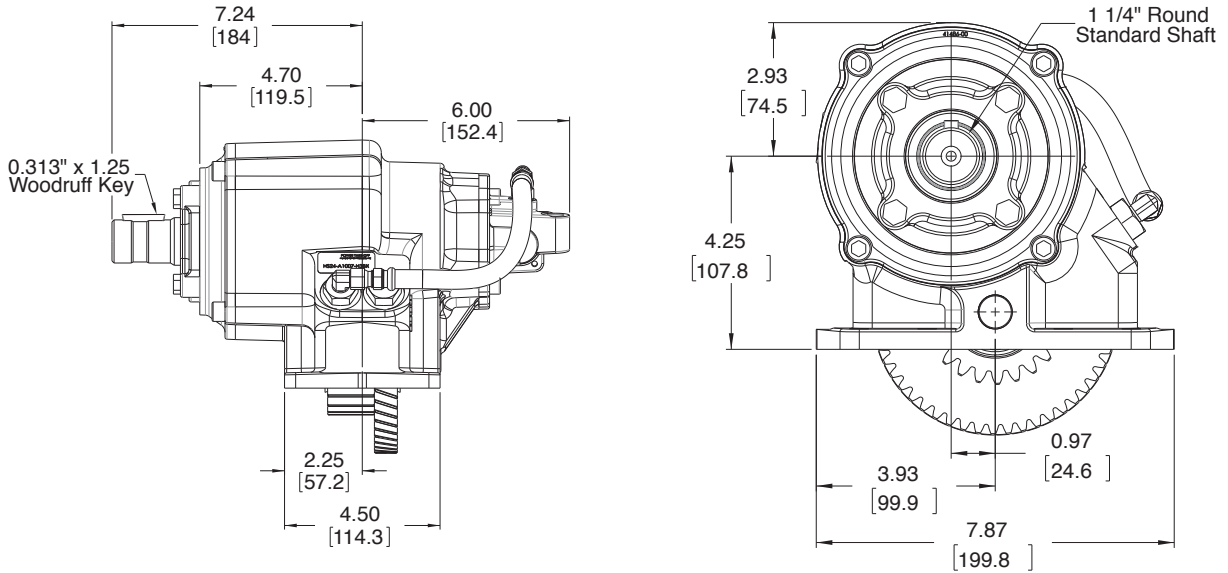

## "K" OUTPUT OPTION — SAE 'B' 2- & 4-Bolt with 7/8"-13T "P" OUTPUT OPTION — SAE 'B' 2- & 4-Bolt with 1"-15T

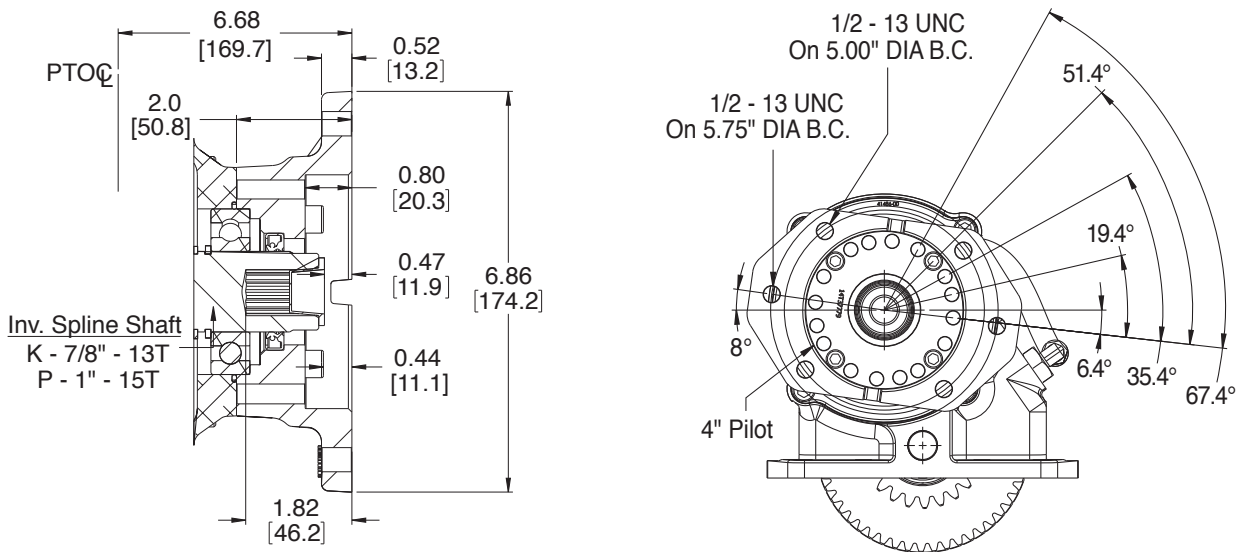

# HS24 PTO DIMENSIONS IN INCHES (MM)

“Q” OUTPUT OPTION — SAE ‘A’ 2-Bolt with 7/8”-13T

“T” OUTPUT OPTION — SAE ‘B’ 2-Bolt with 3/4”-11T

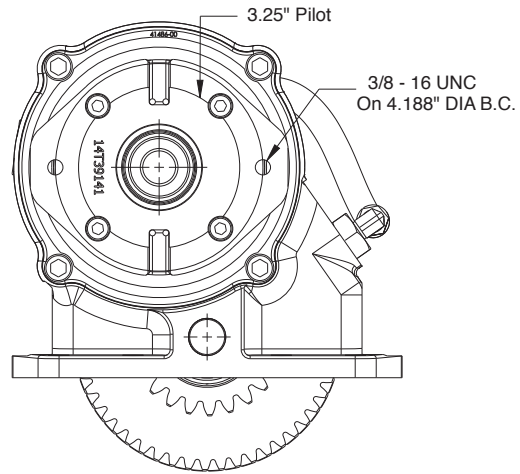
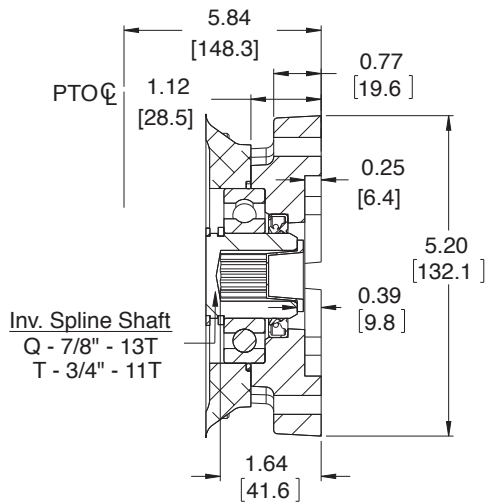

“S” OUTPUT OPTION — SAE ‘B’ 2-Bolt with 7/8”-13T

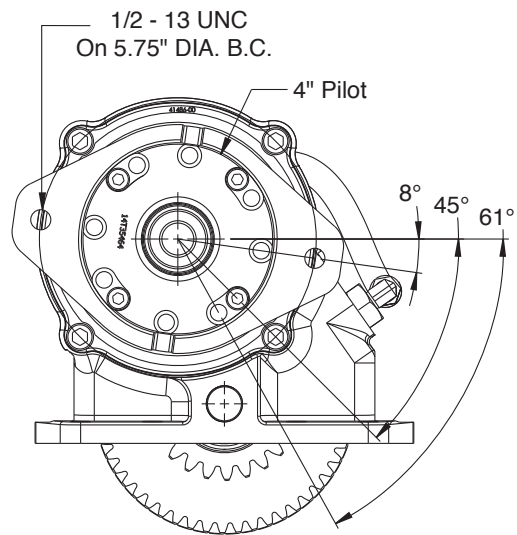
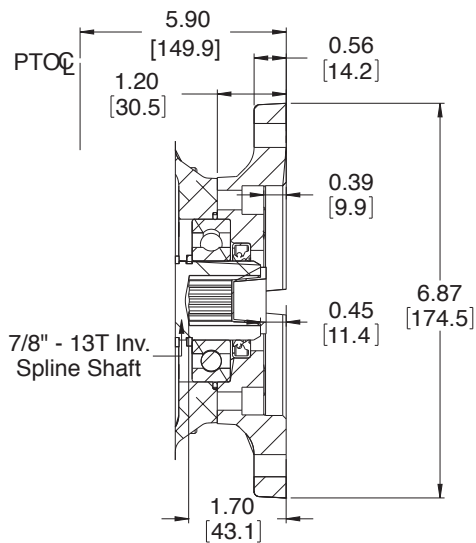

“6” OUTPUT OPTION — SAE ‘B’ 2-Bolt with 7/8”-13T

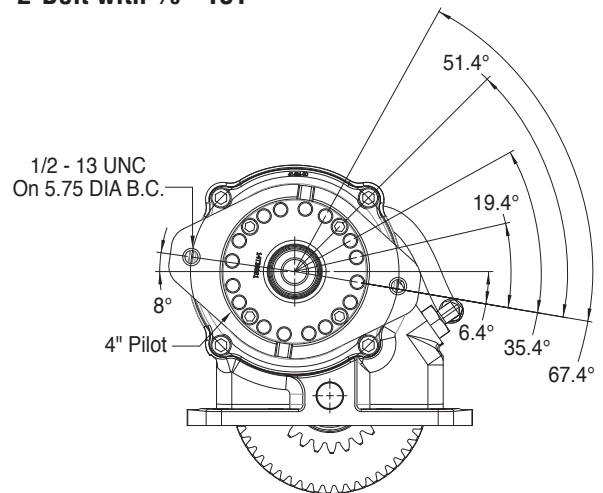
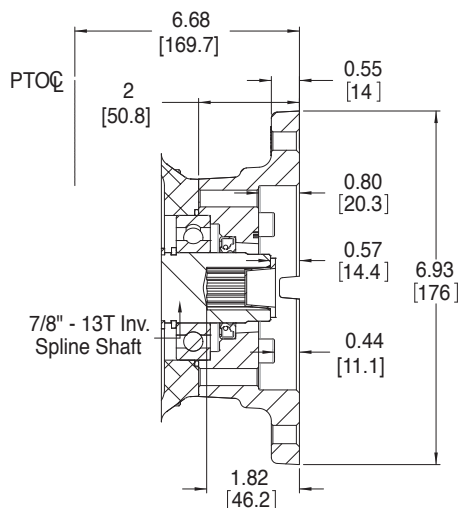



# ACCESSORY KITS

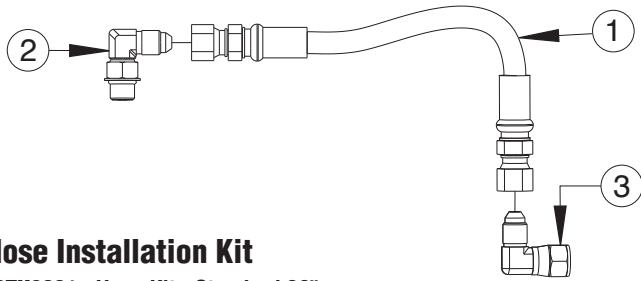

## Hose Installation Kit

- 48TK3881: Hose Kit - Standard 28"
- 48TK3885: Hose Kit - Top R.S. 4000 Series 25" (Optional)
- 48TK4545: Hose Kit - Special 17" (Optional)
- 48TK5163: Hose Kit - Top R.S. 3000 Series 36" (Optional)

ITEM	QTY.	PART NO.	DESCRIPTION
1	1	45T36274	Hose Assembly - Standard 28"
		45T36273	Hose Assembly - HD Top 57"
		45T39186	Hose Assembly - Special 17"
		45T38840	Hose Assembly - HD Top 36"
2	1	43M68014	Elbow (Transmission)
3	1	43T36445	Elbow (Use As Needed) (43TK3881 & 43TK4545 Only)

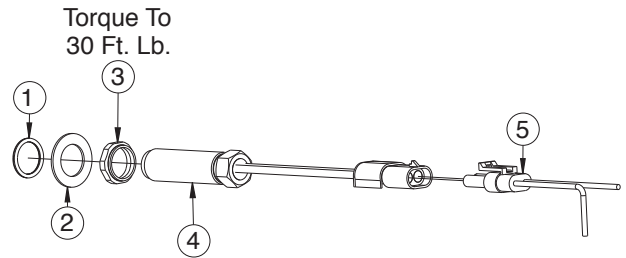

## Speed Sensor Kit - Option "U" — 31TK3873

ITEM	QTY.	PART NO.	DESCRIPTION
1	1	21T41900	Seal Washer
2	1	21T35603	Flat Washer
3	1	21T35109	Jam Nut
4	1	31T35108	Mag Pickup
5	1	34MA1415	Wiring Harness

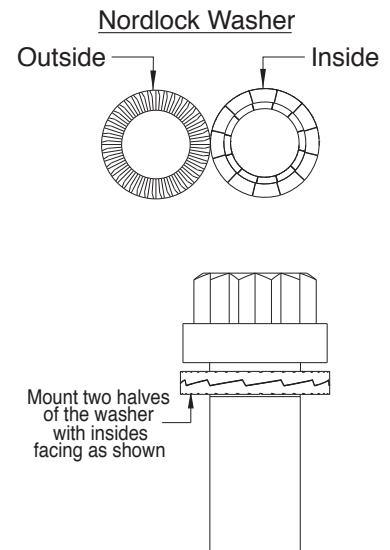
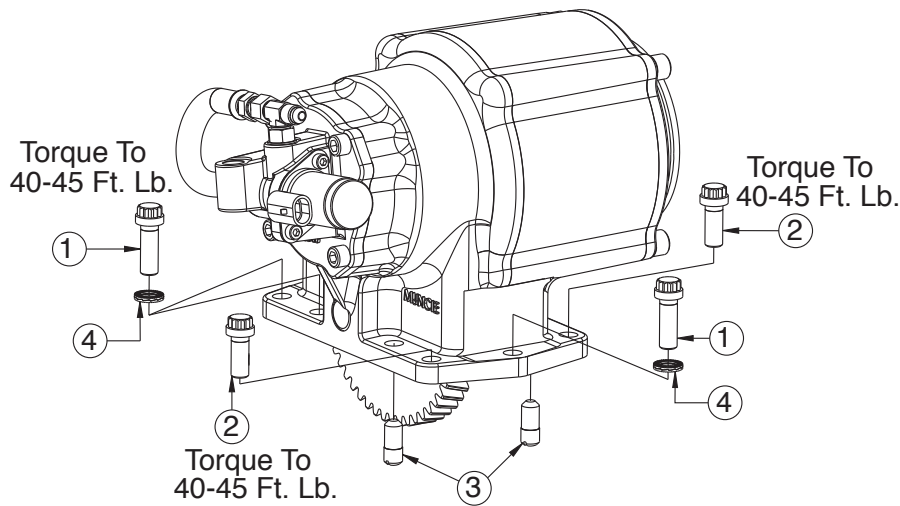

## HS24 Bolt Kit — 20MK1001

ITEM	QTY.	PART NO.	DESCRIPTION
1	6	19T40266	12 Pt. Capscrew - 30mm
2	2	19T37727	12 Pt. Capscrew - 25mm
3	2	20T35779	Alignment Stud
4	6	21T40360	Nordlock Washer

**IMPORTANT:** The HS24 includes the mounting kit, special shim/gasket, high pressure hose hookup kit, wiring harness, dash bracket, and the installation instructions. The PTO is available with the pulse generator (pick-up) for use with the Muncie Digital Tachometer - 38MK2000 (request MP92-04), or use with the Muncie digital switch SPD-1001D to control the engagement or overspeed protection of the PTO. Contact your Muncie Application Specialist for assistance with these options.

# HS24 PTO DISASSEMBLY

## DISASSEMBLY PROCEDURE

Avoid contact with any oil that may escape from the HS24 PTO during the disassembly process because it may be HOT.

1. Remove the input gear (32) by removing the set screw (34) in the mounting pad and driving the input shaft (30) from the housing (37).
2. Next remove the bearing cover (51) by removing the hose assembly (40) from the tee fitting (47) using a  $\frac{9}{16}$ " wrench.
3. Remove the four socket capscrews (50) from the bearing cover (51) using a  $\frac{5}{16}$ " Allen wrench. Remove the bearing cover from the PTO housing. *See Figure 1*

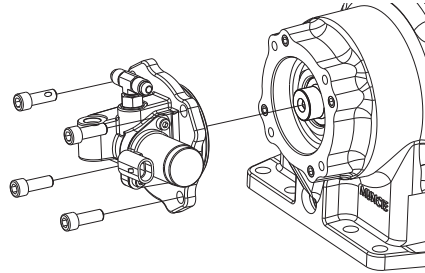

Figure 1 – Bearing Cover Removal

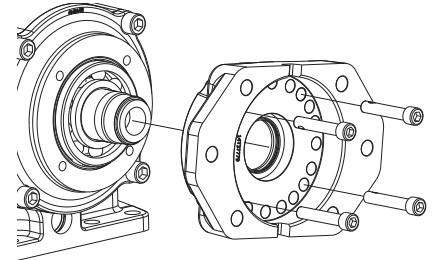

Figure 2 – Flange/Seal Assembly Removal

4. Remove the flange/seal assembly (26) by removing the four socket capscrews (hex head capscrews for a "B" output) (27) from the flange (26) using a  $\frac{5}{16}$ " Allen wrench ( $\frac{9}{16}$ " wrench for "B" output). *See Figure 2*
5. Remove the output cover (22) by removing the O-Ring (25) and the four socket capscrews (23) using a  $\frac{1}{4}$ " Allen wrench. *See Figure 3*

6. Next, position the housing (37) against a bench block and hit the end of the output shaft (10) with a soft face hammer to remove the entire output shaft assembly from the housing (37). *See Figure 4*

7. Using a bearing puller, remove the rear bearing (1) by grabbing the drag brake plate (2) and removing both pieces. The bronze disk (3) can be removed. *See Figure 5*

8. Insert four  $\frac{1}{4}$  – 20 capscrews into the drag brake rotor (4) until they just touch the back of the bell gear. Using an "X" pattern screw the capscrews in at  $\frac{1}{4}$  turn intervals until the brake rotor is free of the output shaft (10). *See Figure 5*

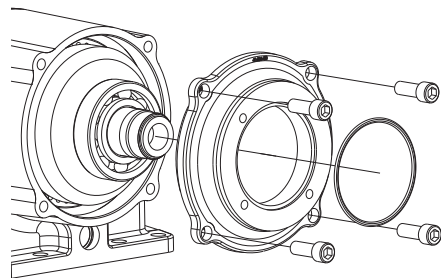

Figure 3 – Output Cover Removal

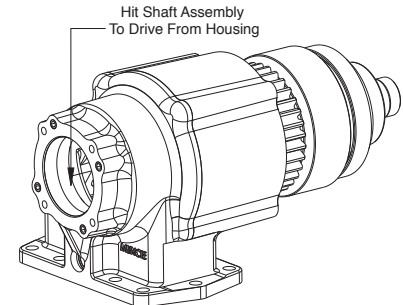

Figure 4 – Output Shaft Drive

9. Using a bearing puller, remove the front bearing (1). Using snap ring pliers, remove the snap ring's (19) located on the front end of the output shaft while gently pushing on the piston cup (18). *See Figure 6*

**Note:** The piston and clutch pack may be serviced without removal of the drag brake.

10. Pull the piston cup (18) from the shaft and the piston (16) will go with it. *See Figure 6*

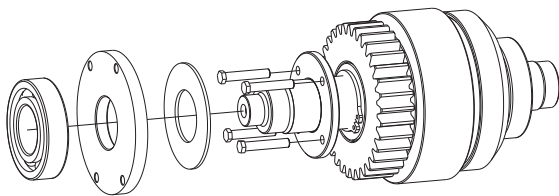

Figure 5 – Output Shaft Component's Removal

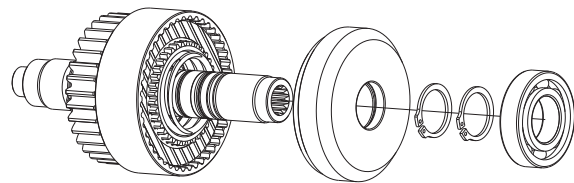

Figure 6 – Output Shaft Component's Removal

11. Tap the piston cup (18) on a wood surface to remove the piston (16).
12. Remove the spring (14). The clutch friction discs (12), spacer discs (13) and clutch hub (11) can be removed by pointing the shaft end down. *See Figure 7*
13. With the drag brake removed, the snap rings (5 & 6) on this end of the bell gear can be removed with snap ring pliers. Proceed to remove the thrust washer (7) and the bell gear (8) to be removed towards the rear of the shaft. The internal bearing (9) of the bell gear can be removed. *See Figure 8*

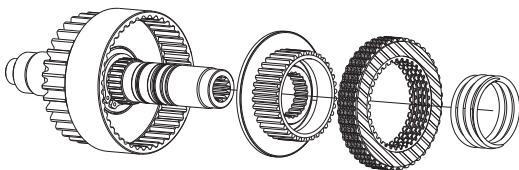

Figure 7 – Output Shaft Component's Removal

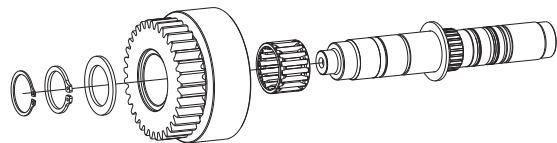

Figure 8 – Output Shaft Component's Removal

# HS24 PTO REASSEMBLY

## REASSEMBLY PROCEDURE

1. The reassembly of the unit is made in reverse of the disassembly. The re-use of seals, O-Rings and snap rings are not recommended. See page 4 for gasket and rebuild kits.
2. Be sure to lubricate all O-Rings and bearings upon installation. Torque all capscrews to the appropriate values:
  - Step #3 – Four socket capscrews for bearing cover – 18 ft.lb.
  - Step #4 – Four socket capscrews for output flange – 18 ft.lb.
  - Step #5 – Four socket capscrews for output cover – 33 ft.lb.
3. The input gear sub assembly is replaced as a set which includes the gear (32), cone spacer (31) and bearings (29). Slide this sub assembly into the housing to line up the input shaft (30).  
*See Figure 9*
4. Insert the shim (28) between the bearing and the housing with the curved end towards the mounting pad (on the set screw side of the mounting pad). Tap the input shaft into the housing and through the bearing races. *See Figure 10*
5. Tap the input shaft in the reverse direction so that it is flush with the bearing in this assembly. Insert the thickest shim (33) that can be installed by hand in the gap between the bearing and housing. Remove the shim (33) and select the next thickest shim and drive into the gap. Rotating the gear to make sure it easily rotates. The recommended bearing pre-load is .002" to .006" loose (the cone spacer sets this pre-load and the measurement is not required). *See Figure 11*
6. Tap the input shaft (30) into position and install the set screw (34). Torque the set screw to 3 ft.lb.  
*See Figure 12*

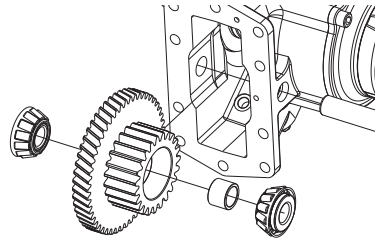

Figure 9 – Input Gear Assembly

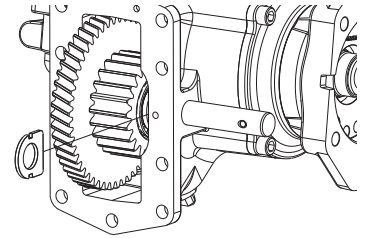

Figure 10 – Shim Installation

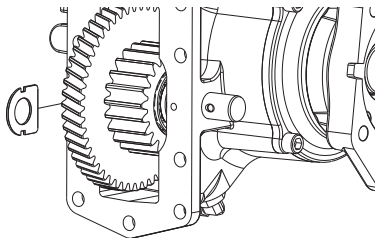

Figure 11 – Shim Pre-load

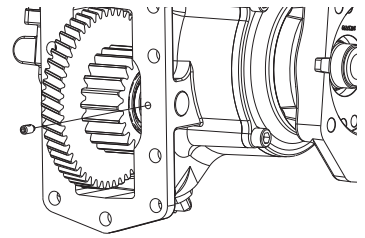

Figure 12 – Securing Input Shaft

## DROP-IN SOLENOID VALVE INSTALLATION

7. Valve is pushed into the housing cavity.
8. Use two 5mm capscrews (48) to mount the solenoid (49). Torque the capscrews to 2-3 ft.lb.

## DRAG BRAKE ADJUSTMENT

9. Remove the hose (40) with a 7/16" wrench. *See Figure's 13 & 14.*
10. Remove the four socket capscrews (50) using a 1/4" Allen wrench. Proceed to remove the bearing cover (51). *See Figure 15*
11. Locate the adjustment screws (42) on the inside of the PTO housing (37). *See Figure 15*
12. Using a 3/16" Allen wrench, turn each of the set screws (42) 1/4 turn clock-wise to increase the drag brake.
13. Move away from under the vehicle and away from possible moving components and restart the engine. Look for the output shaft (10) to stop turning. If the shaft continues to turn, then shut off the engine and repeat steps 11-13.

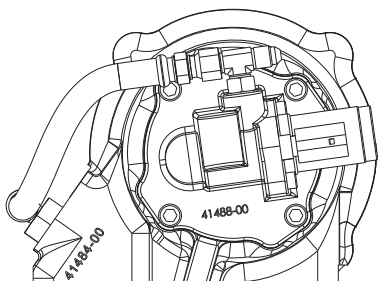

Figure 13 – Hose Removal

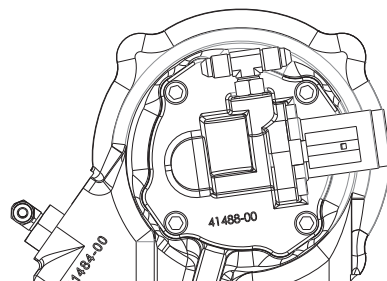

Figure 14 – Hose Removed

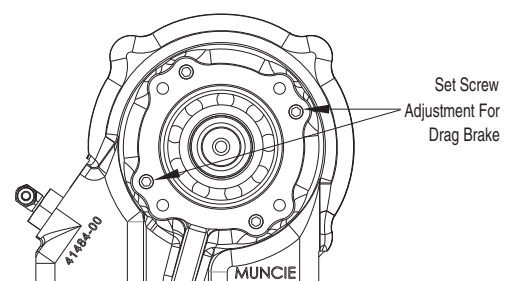

Figure 15 – Drag Brake Adjustment



**Muncie<sup>®</sup>  
Power  
Products**

*Member of the Interpump Group*

SP10-10 (Rev. 12-17)

---

201 East Jackson Street • Muncie, Indiana 47305  
800-367-7867 • Fax 765-284-6991 • [info@munciepower.com](mailto:info@munciepower.com) • [www.munciepower.com](http://www.munciepower.com)  
Specifications are subject to change without notice. Visit [www.munciepower.com](http://www.munciepower.com)  
for warranties and literature. All rights reserved. © Muncie Power Products, Inc. (2010)